

Rain Water Conditioning of Las Vegas



**Rain Water Conditioning
of Las Vegas**

RAIN GRO-475 4-STAGE REVERSE OSMOSIS WATER FILTRATION SYSTEM INSTALLATION AND OPERATION MANUAL

702-257-PURE (7873)

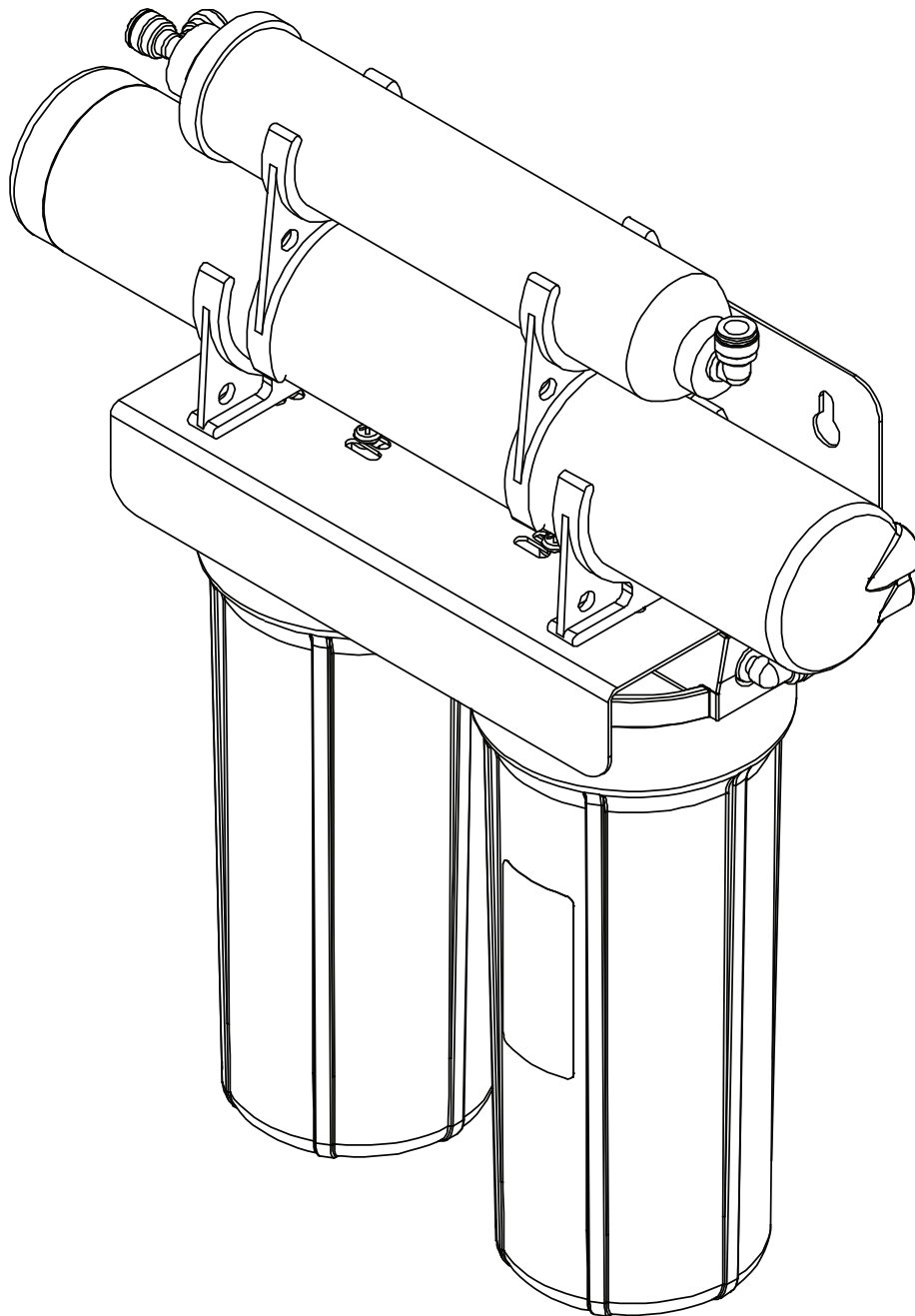

IMPORTANT: Before installing this reverse osmosis system, make certain your water supply complies with the following operating specifications. Failure to do so may reduce the effectiveness of the system and will void the warranty.

SPECIFICATIONS

Thin Film Membrane:	GRO- 75EN
Feed Water Pressure:	40 to 100 psi (2.75–6.9 bar)
Temperature Range:	40–100°F (4.4–37.7°C)
TDS:	2000 ppm
Maximum Hardness [†] :	20 gpg (342 mg/L)
Sulfide, Iron and Manganese [‡] :	0 ppm <0.1 ppm
Chlorine in Water Supply:	Less than 3 ppm
pH Limits:	3–11

[†]If the hardness of your water is above 20 gpg (342 mg/L), lime scale will build up rapidly on the membrane. Scale buildup will plug the membrane and make the system ineffective. We do not recommend these reverse osmosis systems to be used with water in excess of 20 gpg (342 mg/L) hardness.

[‡]A maximum total level of approximately 0.01 ppm sulfide, iron or manganese is permissible. See your local dealer to reduce these substances in your water.

PARTS INCLUDED: (SEE BACK OF MANUAL FOR DIAGRAM)

Pre-assembled filter system (mounting bracket, encapsulated membrane element, pre- and post-filter housings and pre- and post-filter cartridges).

- Storage tank
- Inlet supply adapter
- Drain clamp
- 1/4-inch Tubing
- Tank valve
- Chrome faucet
- Feed tubing
- 3/8-inch Tubing

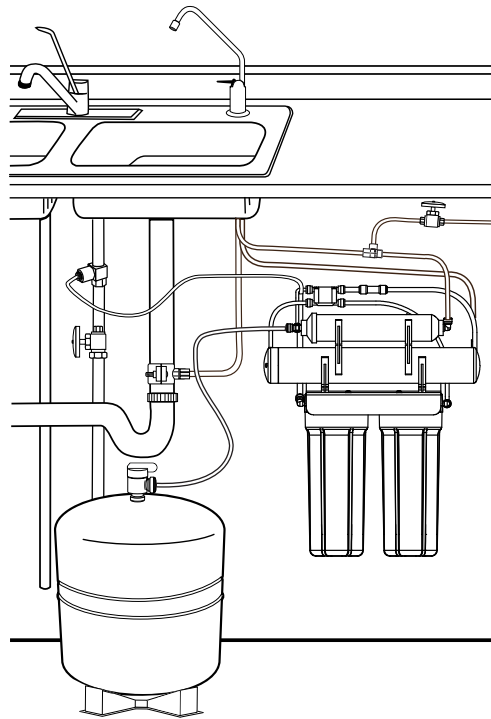

SYSTEM DIMENSIONS:

Overall Dimensions:	15-inch W x 5½-inch D x 17¼-inch H (38.1 cm W x 12.7 cm D x 43.8 cm H)
Weight:	18 lbs. (8.16 kg)
Tank Dimensions:	13½-inch W x 9 inch D x 9 inch H (34.29 cm W x 22.86 cm D x 22.86 cm H)
Tank Capacity Max:	3.2 gal. (10.6 L)
Tank Air Pressure Empty:	5 to 7 psi (0.34 to 0.48 bar)
Tank Weight (Full):	28.5 lbs. (12.9 kg)

Tools and Materials Required

- Hand or electric drill (cordless preferred)
- (2) Adjustable wrenches
- Slotted and Phillips screwdrivers
- File
- Safety glasses
- Drill bits: 1/8", 3/16", 1/4", 3/8"

If sink does not have hole for separate faucet:

- Center punch
- Cone-shaped grinding wheel
- 1-1/4" hole saw or drill bit
- Safety mask

NOTE: All tools may not be necessary for installation. Read installation procedures before starting to determine what tools are necessary.

PRECAUTIONS

GENERAL

⚠ WARNING: Do not use with water that is microbiologically unsafe or of unknown quality without adequate disinfection before or after the system. Systems certified for cyst reduction* may be used on disinfected waters that may contain filterable cysts.

*NSF/ANSI Standard 58 certified to reduce cysts such as *Cryptosporidium* and *Giardia* by mechanical means.

CAUTION: Filter must be protected against freezing, which can cause cracking of the filter and water leakage.

CAUTION: Because of the product's limited service life and to prevent costly repairs or possible water damage, we strongly recommend that the bottom of all plastic housings be replaced every five years for clear and ten years for opaque. If the bottom of your housing has been in use for longer than this period, it should be replaced immediately. Date the bottom of any new or replacement housing to indicate the next recommended replacement date.

NOTE:

- Your water must be within required limits for satisfactory operation. If not, your membrane life may be shortened and your warranty will be voided (see Specifications on page 1).
- This reverse osmosis system will not protect against disease-causing bacteria or remove naturally-occurring harmless bacteria.
- Install on cold water line only.
- Do not use wicking or sealer to fit connections into the cap of the filter. Plumber tape is recommended.
- Make certain that installation complies with all state and local laws and regulations.
- The replacement cartridges and reverse osmosis element included with this system have limited service lives. Changes in taste, odor, and color of the water being filtered indicate that the cartridge should be replaced (see Replacing the Pre- and Post-Filters on page 9, and Replacing the osmosis element, on page 10).
- After prolonged periods of non-use (such as during a vacation) it is recommended that the system be flushed for 5 minutes before it is used.
- A drinking water cartridge may contain carbon fines (very fine black powder). After installation, flush the system for 5 minutes to remove the carbon fines before using the water.
- It is recommended that you run the tap at least 20 seconds prior to using water for drinking or cooking purposes.
- The contaminants or other substances removed or reduced by this water treatment device are not necessarily present in your water.

RO MEMBRANE PRECAUTIONS

CAUTION: Chlorine will destroy the GRO-EN reverse osmosis element. If you use the GRO-450 with a chlorinated or periodically-chlorinated water supply, it is **ABSOLUTELY NECESSARY** to use a carbon pre-filter (included with the system). The carbon pre-filter should be changed at least every 12 months to avoid chlorine bypass.

NOTE:

- To make sure no chlorine is present in the water that reaches the membrane, you may want to use a chlorine test kit to check the brine/reject water that flows from the membrane to the drain. No chlorine should be detected.
- The GRO-50EN element is resistant to naturally-occurring bacteria.

HOW REVERSE OSMOSIS WORKS

The GRO-4550 Reverse Osmosis (RO) System uses a semi-permeable membrane to reduce dissolved salts and minerals, improving the taste and odor of your water. The RO membrane is made of layers of micron-thin film wound around a hollow center core. Water molecules can pass through the membrane, but dissolved salts and minerals are rejected.

The GRO-450 Reverse Osmosis System features 4-stage filter action. Your water supply is pre-filtered to reduce dirt and chlorine that may foul the membrane. The RO membrane separates this pre-filtered water into **PRODUCT WATER** and **DRAIN** or **REJECT WATER**. Incoming water pressure forces the product water through the membrane and into the storage tank. Dissolved solids and other contaminants cannot pass through the membrane and are sent to the drain as reject water. When you open the drinking water faucet, product water is drawn from the storage tank through an activated carbon post-filter, providing you with cleaner, great-tasting water.

For each gallon of water produced, several gallons are discharged as reject water. The storage tank can hold up to 2.8 gallons (10.6 L) of water at a time, for drinking and cooking needs. When used under the Specifications on page 1 of the manual, your Reverse Osmosis membranes should last 48-60 months.

BASIC INSTALLATION PROCEDURE GUIDELINES

- For standard, under-sink installation on 3/8-inch (10 mm) steel, brass, or copper cold water line.
- Please read all instructions and precautions before installing and using your GRO-450.
- Numbered diagrams correspond with numbered steps.

INSTALLATION

- Read all installation and operating instructions before installing and using your RO system.
- Numbered diagrams correspond with numbered steps.

1. Installing the Water Supply Adapter

The supply adapter fits 1/2 NPS threaded connections. If local codes permit, it may be used to connect the GRO-2550 to the cold water supply line. If local codes do not permit the use of the supply adapter, alternate connectors can be obtained from your local plumbing wholesaler.

Directions:

- (A)** Turn off cold water inlet supply line. If cold water line does not have a shut-off valve under the sink, you should install one.
- (B)** Turn on the cold water faucet and allow all water to drain from line.
- (C)** Disconnect cold water line from the bottom of main faucet.
- (D)** Install the water supply adapter into the cold water line.

INSTALLATION CONTINUED...

2. Selecting the Faucet Location

The drinking water faucet should be positioned with function, convenience and appearance in mind. An adequate flat area is required to allow faucet base to rest securely. The faucet fits through a 1¼-inch hole. Most sinks have pre-drilled 1½-inch or 1⅝-inch diameter holes designed for spray hoses. The drinking water faucet may be installed using one of these holes, despite their larger size. If these pre-drilled holes cannot be used or are in an inconvenient location, it will be necessary to drill a 1¼-inch hole in the sink or through countertop next to the sink for the faucet.

CAUTION: This procedure may generate dusts which can cause severe irritation if inhaled or come in contact with the eyes. The use of safety glasses and safety mask for this procedure is recommended.

CAUTION: Do not attempt to drill through an all-porcelain or porcelain-coated sink. For applications on these types of sinks, we recommend using the sprayer hole or mounting the faucet through the countertop.

CAUTION: When drilling through a countertop, make sure the area below the drilled area is free of wiring and piping. Make certain that you have ample room to make the proper connections to the bottom of the faucet.

CAUTION: Do not drill through a countertop that is more than 1 inch thick.

CAUTION: Do not attempt to drill through a tiled, marble, granite or similar countertop. Consult a plumber or the countertop manufacturer for advice or assistance.

The following instructions apply to stainless steel sinks ONLY.

- (A) Line bottom of sink with newspaper to prevent shavings, parts or tools from falling down the drain.
- (B) Place masking tape over the area to be drilled to help prevent scratches if drill bit slips.
- (C) Mark point with center punch. Use a 1/4-inch drill bit to drill a pilot hole through sink.
- (D) Use a 1¼-inch hole saw to enlarge hole. Smooth rough edges with a file.

3. Mounting the Faucet

- (A) Loosen stem-nut on faucet, remove metal slotted disc (if attached).
 - (B) Attach large diameter 3/8-inch drain tube to barb fitting at the faucet base. This tube should be long enough to reach the drain clamp in Step 4.
 - (C) Locate the small diameter 1/4 inch drain tube connected to the drain port of the GRO element. Route the tubing to the faucet and cut off the excessive length of tubing. Retain extra tubing for connecting storage tank to RO system.
 - (D) Attach 1/4 inch drain tubing from RO system to other barb fitting at faucet.
 - (E) Slide chrome plate and black rubber washer onto faucet by threading both drain tubes through the holes on the plate and washer.
 - (F) Slide white extension onto long threaded section of faucet. Open end of extension should come in contact with base of faucet.
 - (G) Apply 3-5 wraps of plumber tape to faucet stem. Screw quick connector onto end of threads.
 - (H) Wet end of 3/8" tube. Push into bottom of connector. Tug gently to be sure connection is complete.
- NOTE:** To remove the tube, push on the fittings' collar and pull the tube out.
- (I) Holding the faucet, feed the three tubes through the hole in the sink. Position the faucet handle at a desired location
 - (J) Center the faucet and slip slotted disc between the white extension and the bottom of the counter or sink. Tighten the stem nut with a wrench until it is tight.
 - (K) Firmly insert goose-neck spout into faucet base.

4. Installing the Drain Clamp

NOTE: If you have a single-basin sink with a disposal unit, call Technical Support for options.

NOTE: Before installing the drain clamp, check the drainpipes under the sink

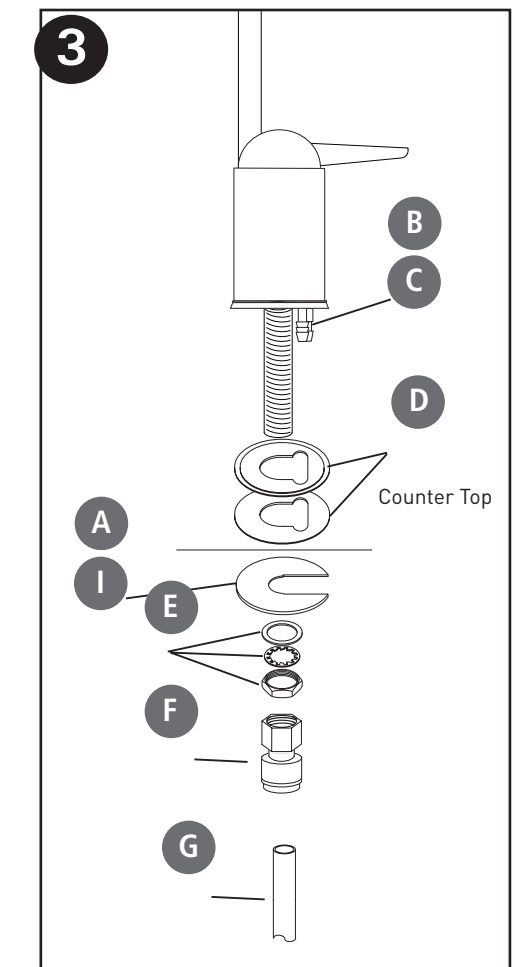
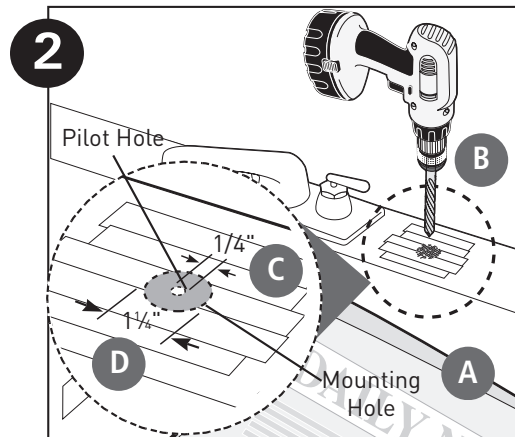
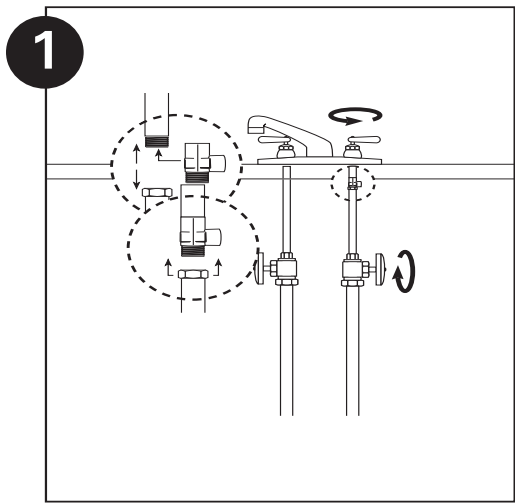

for corrosion. Corroded pipes should be replaced before continuing with installation.

- (A) Attach the drain clamp to a vertical section of the drainpipe, about 6 inches above the trap. Make sure the opening on the drain clamp is facing towards the drinking water faucet (see diagram on previous page).
- (B) Using the fitting hole of the drain clamp as a guide, drill a 1/4-inch hole through one side of the drainpipe.
- (C) Remove the drain clamp from the drainpipe and enlarge the hole with a 3/8-inch drill bit. Use a file to remove rough edges from the drilled hole.
- (D) Make sure the black rubber gasket is adhered to the inside of the drain clamp and place the drain clamp assembly over the drilled hole. Look through the hole and position the clamp so that the center of the clamp hole is slightly higher (about 1/16-inch) than the center of the drilled hole. Tighten the clamp securely.
- (E) Screw the plastic compression nut onto the drain clamp until hand-tight.

5. Connecting the Faucet to the Drain

CAUTION: This is a gravity drain line. Any loops, kinks or sharp bends must be eliminated before proceeding. Failure to create a straight line to the drain may result in reject water leaking through the air gap in the faucet onto the countertop and below the faucet.

- (A) Align the larger reject (3/8-inch) tubing from the faucet with the compression nut on the drain clamp. Create as straight and smooth a path as possible with the tubing. Do not kink tube. Cut the tubing squarely below the nut and remove the internal and external burrs.
- (B) Loosen the compression nut two complete turns. Insert the tubing into the nut until it stops. Tighten with fingers, then tighten 1 to 2 turns with a wrench.

6. Installation of Mounting Screws

- (A) If system is being installed under the kitchen sink, locate it on back or right wall. Make sure to allow ample space for installation. To change the filter cartridges, a minimum of 1-1/2 inches of clearance is required underneath the filter housings. A minimum of 2 inches of clearance from the left side of the unit is also required or 5 inches from the left bracket mounting screw hole.
 - (B) Install mounting screws at least 15 inches from cabinet floor and 7 1/2-inches apart. Leave a 5/16-inch space between the head of the screw and the wall to slip bracket onto screws.
- NOTE:** Each connection fitting on the RO Assembly has a plug that must be removed before inserting tubing. Push in on the collar and pull the plug out.

7. Connecting the Faucet to the System

- (A) The faucet tube from the bottom of the threaded metal tube is inserted into the post filter. The fitting is at the top right of the RO System. Push the free end of the tubing into the quick connect fitting.

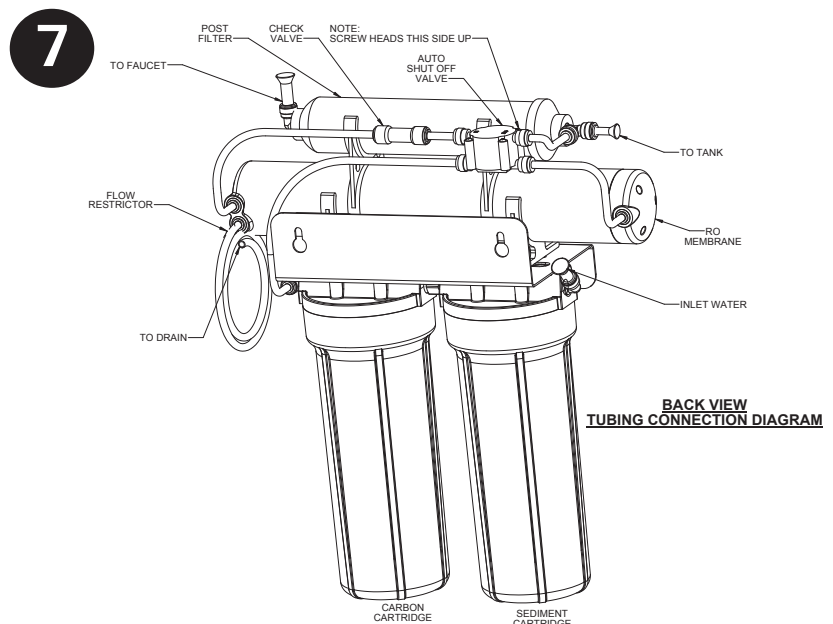
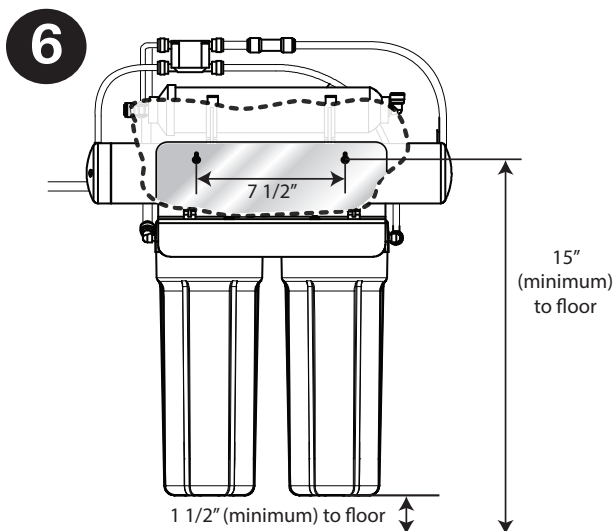
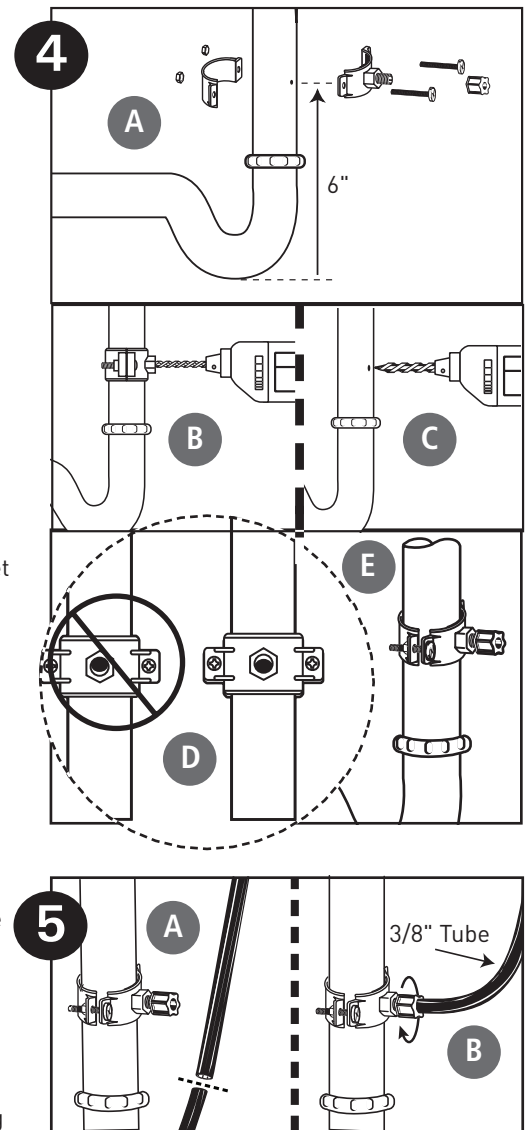

**BACK VIEW
TUBING CONNECTION DIAGRAM**

INSTALLATION CONTINUED . . .

8. Connecting the Storage Tank to the System

CAUTION: When tank is full, it weighs approximately 28.5 lbs. (12.9 kg) Provide ample support under the tank.

(A) To prevent leaks, apply 3 or more wraps of plumber tape to threads on tank. Thread the tank valve onto the top of the tank opening. Turn tank so handle is in line with tubing.

CAUTION: The tank/valve connection will leak if not properly sealed. plumber tape will normally seal the threaded connection.

(B) Locate the remaining length of 1/4-inch tubing. Place a mark on the tubing 5/8-inch from one end. Moisten the marked end of the tubing with water and insert with a twisting motion into the port of the tank valve until the 5/8-inch mark is flush with the quick connect fitting. Then locate the tank near the system's installation area.

(C) Cut the tubing to correct length. Install free end of tubing into white quick-connect fitting on the post filter tee on the left side. Ensure the tubing does not kink.

(D) Place entire system over mounting screws on wall and slide down.

CAUTION: Make certain system is firmly attached to wall to prevent it from falling and possibly becoming damaged.

NOTE: Use caution not to bend or pinch the tubing behind the system while attaching to mounting screws.

9. Connecting the System to the Water Supply Adapter

(A) Locate remaining length of 1/4-inch plastic tubing.

(B) Place a mark on the tubing 5/8-inch from the end. Moisten the end of the tubing with water and insert with a twisting motion push into quick connect fitting on the left side of system. Depending on the installation, the system may need to be removed from the mounting surface to access the left side of the system.

(C) Cut the tube to a length that will allow connection to the Water Supply Adapter. Ensure the tubing does not kink. Place a mark on the tubing 5/8-inch from the end. Moisten the end of the tubing with water and insert with a twisting motion push into quick connect fitting on the Water Supply Adapter.

10. Faucet Operation

(A) For controlled water flow, push the handle down.

(B) For constant water flow, lift the faucet handle to lock it in the open position.

11. System Start-up

NOTE: The reverse osmosis membrane is treated with a food grade sanitizing agent that may cause an undesirable taste. Although it is not harmful, it should be flushed from the system.

NOTE: The post-polishing filter may contain fine black carbon particles. These fines are harmless, but may make the water appear gray in color. The carbon fines are flushed from the system with the first tank full of water.

NOTE: The RO system does not produce a high volume of water on demand as an ordinary filter does. Water is produced at a slow, drop-by-drop rate. The system requires about 2 to 4 hours to fill the storage tank. As water is taken from the tank, the system automatically starts the cycle of replacing the water and then stops water production when the tank is full.

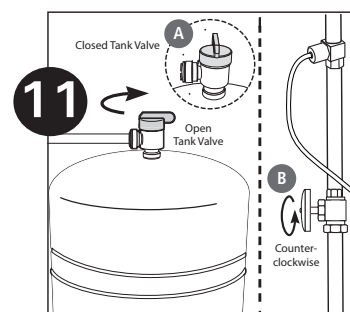
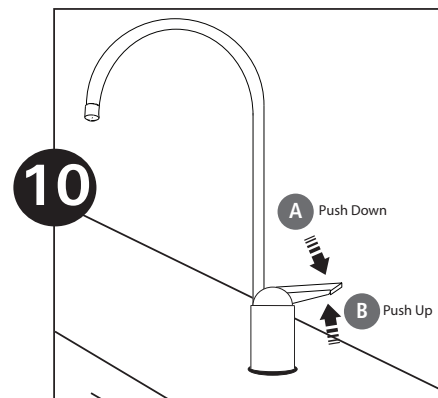
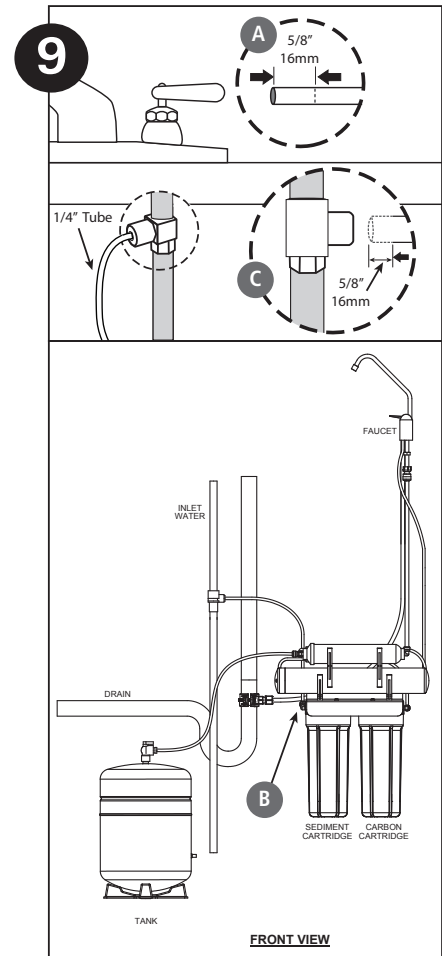
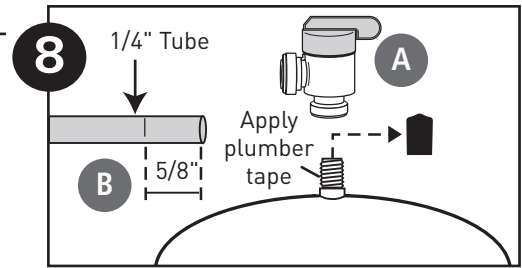

CAUTION: Visually check the entire system for leaks. If a leak is present, see Troubleshooting on page 11.

- (A) Turn off valve at top of storage tank.
- (B) Turn on the cold water supply, and ensure the supply adapter valve is open.
- (C) Lift the faucet handle to lock it in the open position and let it drip for 30 min.
- (D) Completely open the cold water supply until it comes to a stop. Allow water to drip from the faucet for 12 more hours. Then close the faucet and open the valve on the storage tank. The tank valve is open when the handle lines up with the tubing connection.
- (E) Allow 3 hours for the tank to fill. Continue to periodically check the installation for leaks. After the storage tank is filled, open the faucet to flush the post-filter cartridge. Allow 4 to 5 minutes for all of the water to drain from the tank. Close faucet and allow tank to fill.
- (F) Repeat step E four times.

NOTE: Initially, the water may appear cloudy. This is a result of air trapped in the post-polishing filter. It is not harmful and will disappear in a matter of minutes. It may take up to a week after installing a new post-polishing filter for the trapped air to dissipate.

The system is ready for operation. You can now enjoy quality water from your Reverse Osmosis System.

TESTING YOUR REVERSE OSMOSIS SYSTEM

Model GRO-475 Reverse Osmosis System Total Dissolved Solids (TDS) Test

NOTE: It is highly recommended that you (the consumer) have your water tested at least every 12 months to verify that your system is performing satisfactorily.

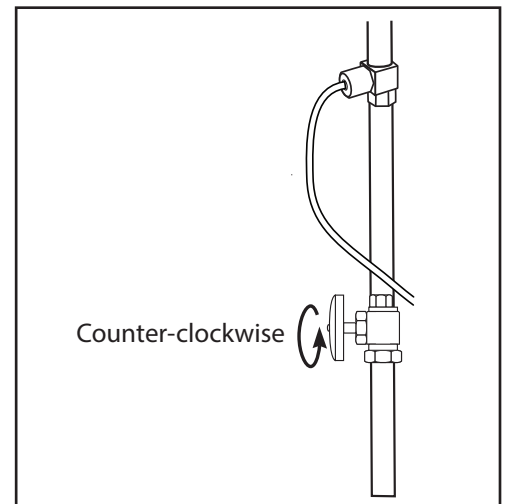
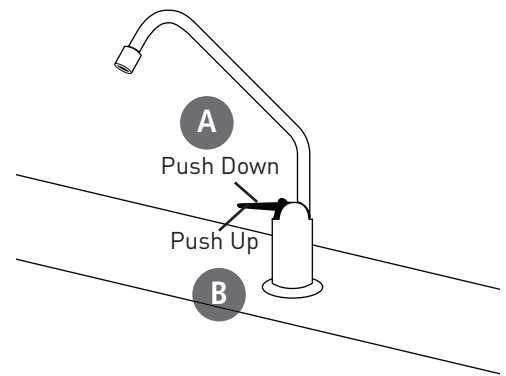

OPTIONAL INSTALLATION

Connecting your Reverse Osmosis System to Refrigerator Icemaker / Water Dispenser

CAUTION: If you are connecting this unit to your refrigerator/icemaker with initial RO installation, wait to turn on the icemaker until the post-polishing filter has been flushed according to Step 11.

CAUTION: Use plastic tubing and fittings. Do not use copper tubing or brass fittings.

NOTE: For optimum performance, it is recommended that the distance between the RO system and the refrigerator icemaker/water dispenser be no greater than 10 feet (3 m). At distances greater than 10 feet, the water pressure from the system may not be adequate to deliver water to the refrigerator.

MATERIALS REQUIRED (available from your local hardware store):

- 3/8-inch x 3/8-inch x 3/8-inch (0.952 cm x 0.952 cm x 0.952 cm) compression or quick-connect tee
- 10 feet (3 m) of 3/8-inch (0.952 cm) polyethylene tubing
- Shut-off valve

1. Turn off refrigerator water supply and icemaker (consult manufacturer's guidelines).
2. Close tank valve (on top of storage tank).
3. Turn off water to RO system at the cold water supply, or at the feed water supply adapter.
4. Open drinking water faucet to relieve pressure.
5. Locate tubing (permeate) leading to your drinking water faucet. Cut and insert the 3/8-inch x 3/8-inch x 3/8-inch compression or quick-connect tee into the permeate tubing. Consult manufacturer's guidelines before installing the supply adapter.

NOTE: When cutting the permeate tubing, you may experience some water leakage.

6. Using a length of 3/8-inch polyethylene tubing, connect the icemaker/dispenser line with the free port on the compression tee.
7. The shut-off valve should be installed as close to this port of the tee as possible. Shut-off valve should be installed in the OFF position. Consult manufacturer's guidelines before installing the shut-off valve.
8. Completely open cold water supply.
9. Open tank valve.
10. Turn off the drinking water faucet.
11. Turn on water to RO system at cold water supply.
12. Turn on icemaker and open shut-off valve. Consult manufacturer's instructions.
13. Check for leaks and tighten connections if necessary.

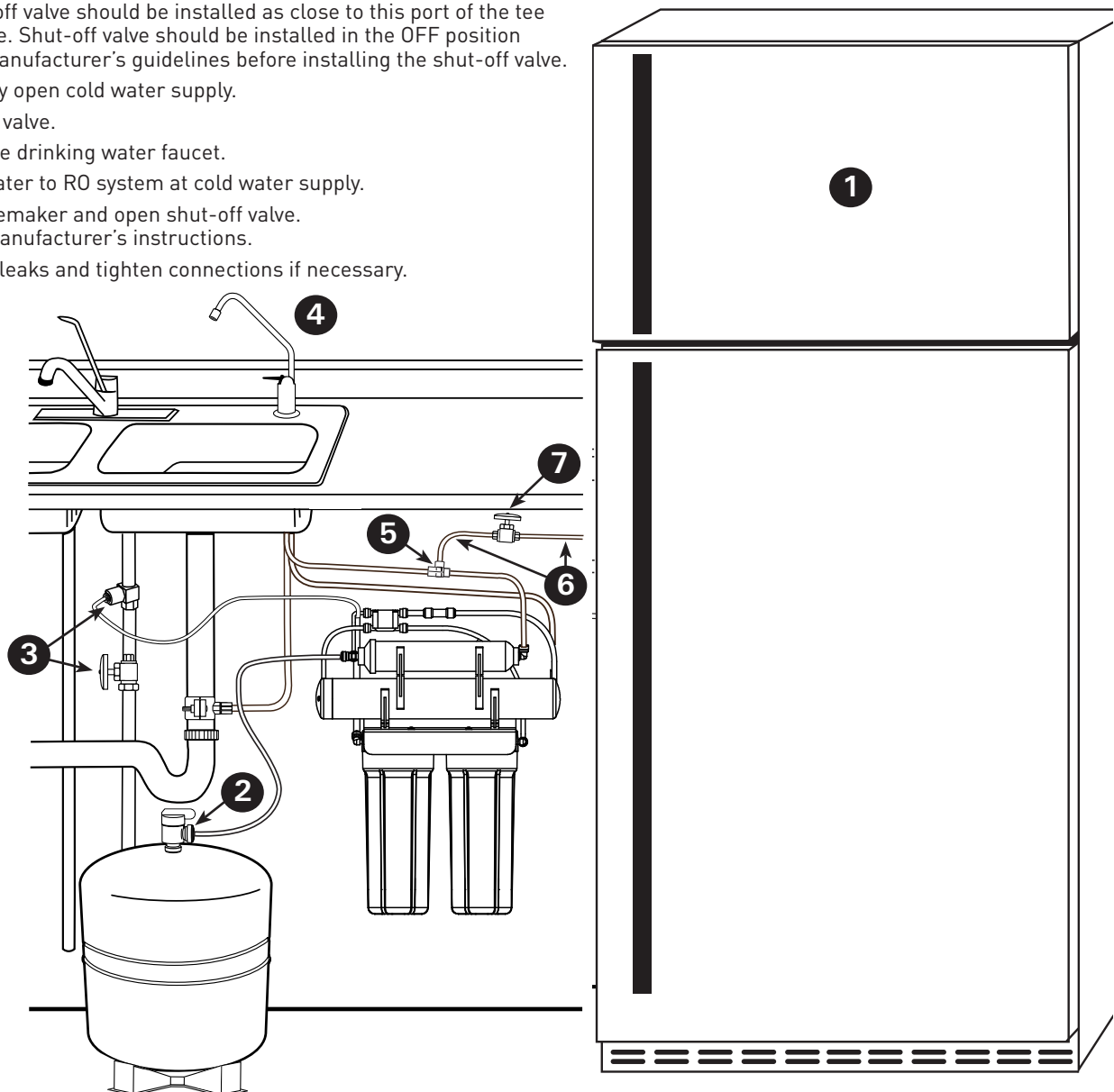

REPLACING THE PRE-FILTER AND POST-FILTER CARTRIDGES

1st Stage Pre-Filter and 2nd Stage Pre-Filter Cartridges: The cartridge should be replaced every 12 months. If your water contains a high amount of sediment, it may be necessary to change the 1st stage cartridge more frequently. If your water contains a high amount of chlorine, it may be necessary to change the 2nd stage pre-filter more often.

1. Turn off incoming water supply and valve on the storage tank. Place a tray under the system to catch any water that spills during removal of the filter housings.
2. Open faucet to release pressure.
3. Unscrew bottom of filter housings from caps. Use the filter wrench. Discard used cartridges.
4. Remove black rubber O-rings from grooves in housings. Wipe grooves and O-rings clean; set O-rings aside.
5. Rinse out housings and fill each 1/3 with water. Add 2 tablespoons of bleach and scrub with non-abrasive brush or sponge. Rinse thoroughly.
6. Lubricate each O-ring with a coating of clean silicone grease. With two fingers, press each O-ring securely into groove below the threads of the appropriate housing.

CAUTION: The rubber O-ring provides the water-tight seal between the cap and the bottom of the housing. It is important that the O-ring be properly seated in the groove below the threads of the housing or a water leak could occur.

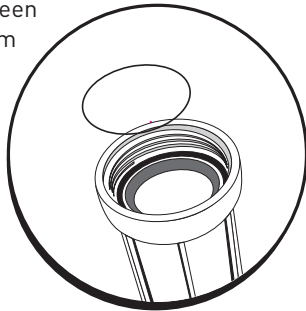

7. Insert cartridges in the bottom of the housings. Make sure cartridge slips over standpipe in the bottom of the housing.

NOTE: Be sure to install cartridges in proper housings (see diagram below).

8. Screw bottoms of housings back onto caps securely; do not over-tighten. Turn on cold water supply. Check for leaks. Continue to check periodically to make sure no leaks develop.

4th Stage Post-Filter Cartridge: post-filter should be replaced every twelve months.

1. Turn off incoming water supply and valve on the storage tank. Place a tray under the system to catch any water that spills during removal of the filter housings.

2. Open faucet to release pressure.

3. Remove filter from bracket and discard.

4. Remove tubes from fittings by pressing in collar around the fitting while pulling the tubing out with your other hand.

NOTE: If quick connect fittings need to be installed, tape threads of fittings with 3 wraps of plumber tape and attach to filter.

CAUTION: Ensure the tape is not touching O-ring on the fitting or a leak may occur.

NOTE: The filter has an arrow on it showing the direction of flow. The tee fitting connects to the inlet side of the filter and the elbow fitting attaches to the outlet side.

NOTE: Hand tighten fittings, then tighten with wrench 1/4 turn.

5. Attach 4th stage filter to bracket with the tee fitting on the right hand side.

6. Attach tubes to fittings by pushing in until the tube stops. Check to see if tube is in place by trying to gently pull tube out.

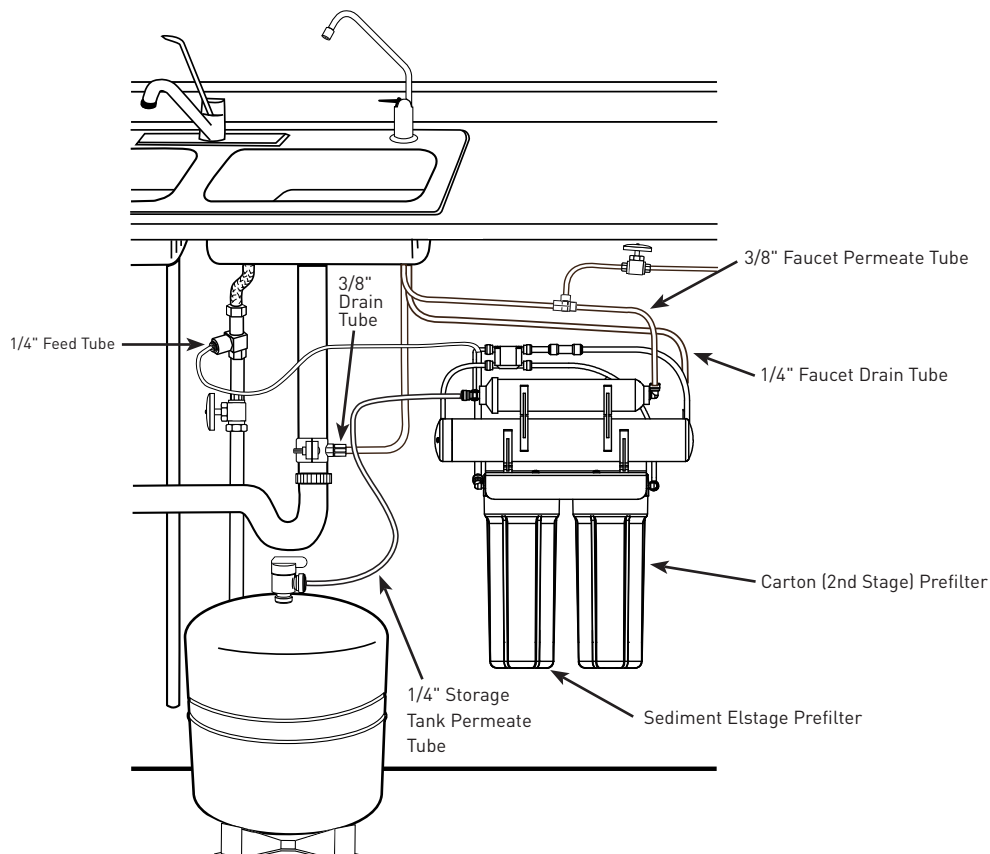

REPLACING THE 3RD STAGE REVERSE OSMOSIS MEMBRANE

About the Reverse Osmosis Membrane

When used under operating conditions specified on page 1 of the manual, your reverse osmosis membrane should last at least one year. You should replace the membrane after 18 to 24 months. Replace it sooner if you notice a return of unpleasant tastes or odors or a noticeable decline in water production. The precise life span of your system's membrane will depend on the quality of the water entering the system and the frequency with which you use it. Frequent system use prevents the filtered salts and minerals from building up on the membrane as scale. The more water the system is required to produce, the longer the membrane will last. You may wish to find a variety of uses for your system in order to prolong the life of the membrane.

NOTE: If system stands for more than 2 to 3 days without being used, the storage tank should be emptied.

Replacing the Membrane and Filters

NOTE: When installing a new GRO membrane element and flow control, it is recommended that you replace the pre-filter and post-filter cartridges as well.

1. Turn off the cold water supply. Allow five minutes for system to depressurize.
Place a tray under the system to catch any water that spills during removal of the filter housings.
2. Open drinking water faucet to drain tank. When tank is drained, close faucet.
3. Disconnect the tubing connections from the GRO element. Install the new GRO element, permeate checkvalve, and capillary reject flow controller.
4. Unscrew filter housings from caps and discard used cartridges.
5. Remove black rubber O-rings from grooves in housings. Wipe grooves and O rings clean. To replace the filters, see Replacing the Pre-Filters and Post-Filter on page 9.
6. Lubricate O-rings with a coating of clean silicone grease. With two fingers, press each O-ring securely into groove below the threads of the appropriate housing.

CAUTION: The rubber O-ring provides the water-tight seal between the cap and the bottom of the housing. It is important that the O-ring be properly seated in the groove below the threads of the housing or a water leak could occur.

NOTE: After installing new GRO element, flow control, and cartridges, allow system to run for 3 hours to fill tank. Check for leaks every hour. As pressure builds in tank, leaks may occur that did not exist directly after installation. When the RO element and cartridges have been changed, follow the system start-up procedure in Step 11: System Start-up.

TROUBLESHOOTING GUIDE

Leaks between bottom of housing and cap

1. Ensure sump is tightly screwed to cap. If it still leaks close the cold water supply and tank valves.
2. Clean black rubber O-ring and lubricate with clean silicone grease. With two fingers, insert O-ring in groove below threads of housing and press into place. Tighten housing back onto cap.
3. Open the cold water supply and tank valve.
If leaks persist, call Technical Support.

Leaks on tank valve assembly

1. Open drinking water faucet to drain storage tank. Let drinking water faucet run until it drips. Turn off cold water supply.
2. Push in on white collar of tank valve fitting and pull out tubing. Unscrew the tank valve from the storage tank. Rewrap threads on top of the tank with plumber tape. Screw tank valve back onto tank. Trim 1/2-inch from end of tubing and reinsert 5/8-inch into tank valve fitting.
3. Open the cold water supply and shut off the reverse osmosis faucet. Let the system pressurize for several hours and check for leaks. Check again after tank is fully pressurized.

Leaks on quick-connect fittings

1. Close the cold water supply and tank valve.
2. Depress plastic collar and pull out tubing.
3. Cut off 1 inch of tubing and place a mark 5/8-inch from end of tubing. Tubing should be cut squarely. The internal and external burrs should be removed.
4. Push tubing 5/8-inch into fitting.
5. Open the cold water supply and tank valve. If leaks persist, call Technical Support.

No flow or slow flow from the brine (drain) line

Less than 1½ cups per minute

NOTE: Before checking brine (or reject) flow, make sure the system is producing water by turning off the valve on the storage tank and opening the faucet. Water should drip from faucet.

1. Examine the pre-filters. If clogged, replace (see Replacing the Pre-Filters and Post-Filter on page 9) and recheck the brine (or reject) flow rate.
2. If the pre-filters are not at fault, the brine (or drain) flow controller is probably clogged. Call Technical Support.

Reduced production

Slow or no product water flow usually indicates either a clogged pre-filter or an exhausted membrane. First, replace the pre-filters. If the production rate is not improved, replace membrane.

Gradual return of taste and odor

Gradual return of unpleasant taste and odor over a period of time may indicate that your filter cartridges and/or RO membrane need to be replaced. See Replacing the Pre-Filters on page 9 and Replacing the Reverse Osmosis Membrane on page 10.

Sudden return of taste and odor

If shortly after complete servicing noticeable taste and odors return contact Technical Support.

No water pressure from the drinking water faucet or low volume in storage tank

1. Close the cold water supply to system.
2. Lift storage tank to see if it is empty. If not, open the drinking water faucet to empty water from tank.

NOTE: It may be necessary to pump a small amount of air into the tank with a bicycle pump to remove all the water from the tank.

3. When tank is empty, use a pressure gauge to check tank pressure. An empty tank should contain 5 to 7 psi pressure. Increase or decrease the air pressure in the tank accordingly.
4. Open cold water supply. Let system run for 3 hours to fill tank, then check system performance. If performance has not improved, call Technical Support.